

Sheet TT-106 A

Cancelling Plan Number TT-59 dated 7-21-19
 " " " TT-106 " 11-1-41

Pressure Plate Welded... Revised - Feb. 13, 1959
 Stop Sign Added..... Revised - Aug. 30, 1949
 Spec. for Steel Post..... " Jan. 6, 1950
 Nelson Welded Stud... " Mar. 11, 1953
 Bolt Flag to Post Apr. 17, 1964

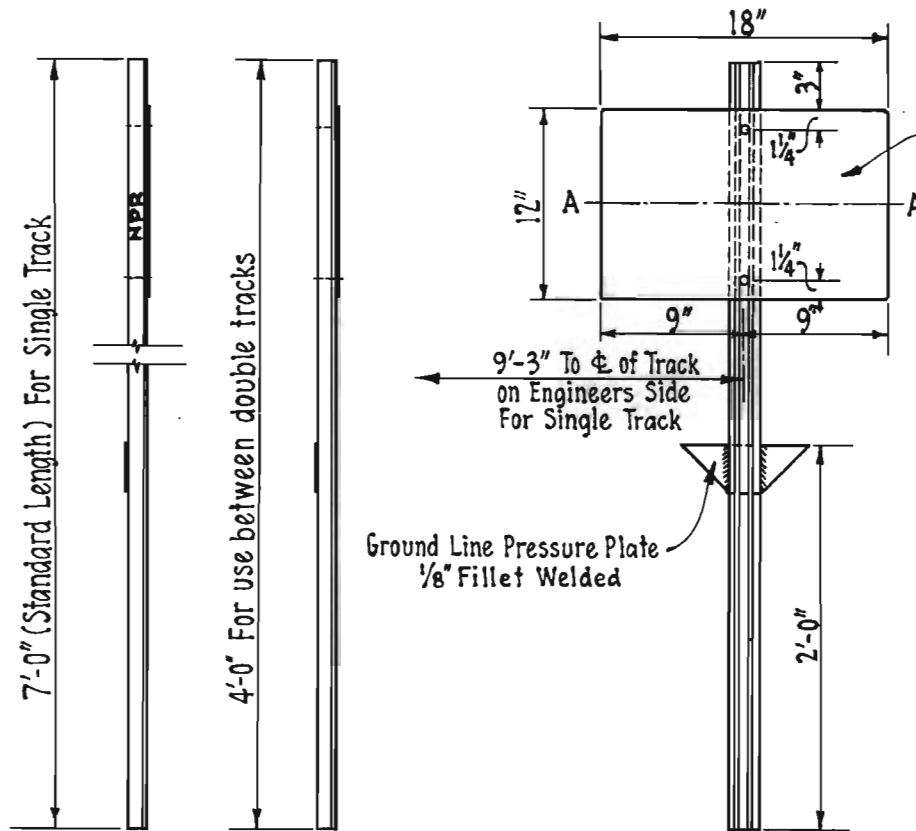

Flag to be made from S.M. sheet steel of approximately 1/8" thickness but not more than 3/16" thickness.

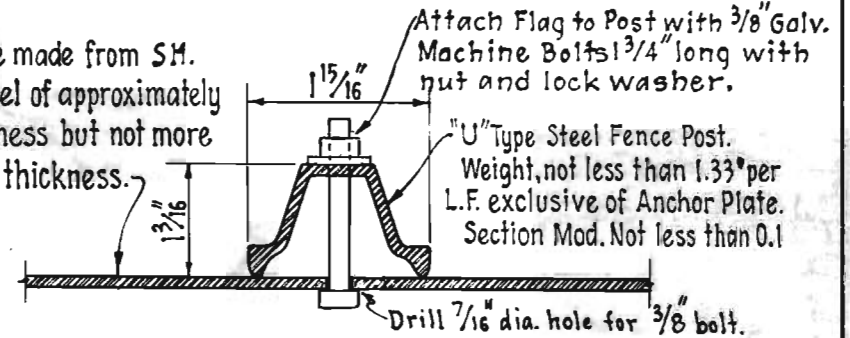

Section A-A
 Scale - Half Size

Stop flag to be faced with red Scotchlite and the back to be painted black.

Caution flag to be faced with yellow Scotchlite and the back to be painted black. Resume speed flag to be faced with green Scotchlite and back to be painted black.

Application of Scotchlite shall conform to Manufacturer's instructions.

Side

Front

Scale: 1" = 1'-0"

*Cancelled April 22, 1968
 superseded by Std. Plan
 6-1-17 Arch. Office*

N.P. Ry.

Standard Plan
 of Track Tools

Stop, Caution and Resume Speed Flags (Sign)

Scale: As Shown

Dec. 11, 1946

Approved:

Bernard Blum
 Chief Engineer

H. J. Stevens
 Vice President